



## 3" Cast Iron & Stainless Steel Pump Instruction Manual

300PI8PRO, 300PIH-8,  
300PIH-11, 300PIH13

Read these instructions and the instructions covering the operation of the engine before starting the engine. Do not operate the engine until you have put oil in the engine crankcase. It is wise to check the oil level each time the gasoline tank is filled. If the pump is used only occasionally, check oil and gasoline before starting engine.

Do not run the pump dry. Always fill the pump body with water (or liquid to be pumped) before starting pump. It is not necessary to drain the pump body after use, unless there is a danger of freezing.

Use a regular grade of gasoline (unleaded and uncolored if available). Remove the engine cylinder head after 100 hours of operation and remove the carbon and lead deposits from the combustion chamber and top of the piston.

Make certain that all hose and pipe connections are air-tight. An air leak in the suction line may prevent priming and will reduce the capacity of the pump.

Always place the pump as close to the liquid to be pumped as possible. Keep the suction line short and with few bends. Keep the pump and engine on a level foundation. A poor foundation and a heavy suction hose (made heavier when "primed" full of liquid) could result in a pump "down the hole".

There are important instructions regarding preparing the engine for long periods of idleness. (Read the engine instruction manual). Under these conditions, drain the pump completely, turn the engine over a few times and leave all plugs (filter and drain) out of the pump. Always try to store the unit in a heated and dry building.

When pumping dirty water or other liquids containing solids, always use a pump strainer on the end of the suction line. There are no points on the pump which need lubrication. The shaft seal is self-lubricating, and designed to handle clean or dirty liquids.

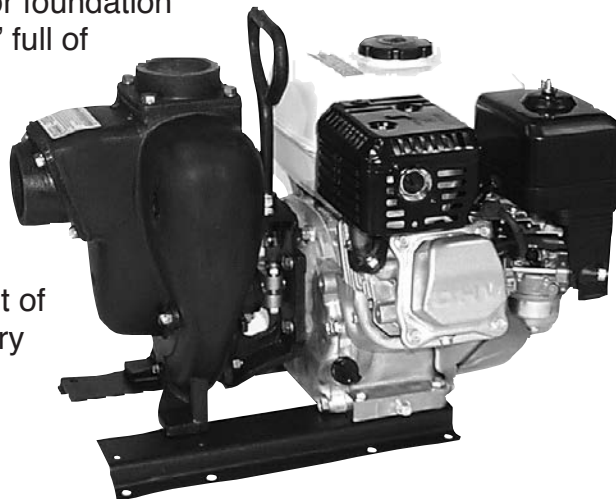
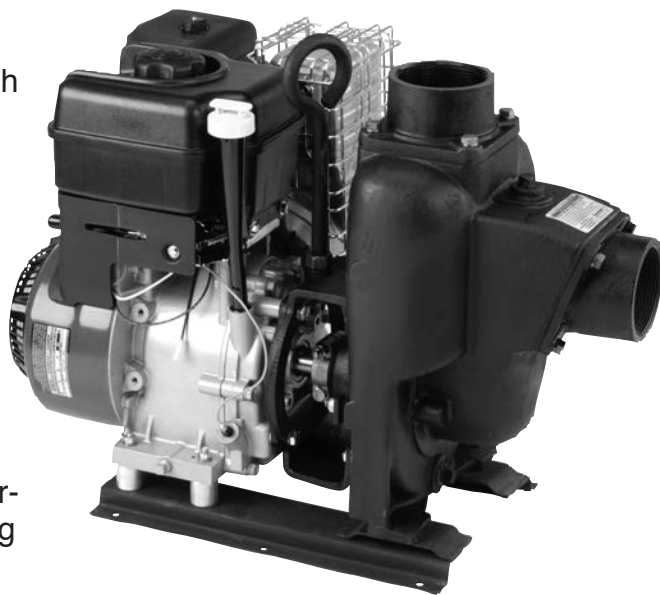

# DISASSEMBLY INSTRUCTIONS:

1. Remove bolted clamp from shaft. Remove (4) bolts holding motor or Bearing Pedestal to the adapter plate.



2. Remove (6) nuts and lock washers holding adapter plate to housing. Using a screwdriver behind the side tabs, gently pry the adapter loose. Remove impeller, drive sleeve and seal assembly.

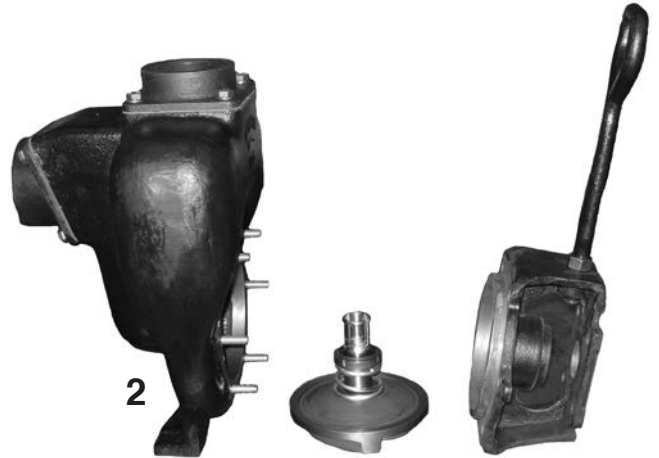

3. Remove two stainless steel flat head screws and remove wear plate. Replace the wear plate when there are surface grooves or excessive wear.

When reassembling, make sure there is no foreign material between the wear plate and the pump housing that would prevent the wear plate from lying flat.

4. Remove the seal and spring from the impeller and drive sleeve. Inspect the surface of the impeller sleeve. The surface can be cleaned with very fine sandpaper (#400) or if excessively worn or grooved, the impeller should be replaced. Remember, a worn impeller can cause an out of balance condition resulting in vibration and seal wear.

Always install a new seal assembly onto impeller before reassembling pump. It is very important not to scratch or mark the black carbon surface of the seal assembly.

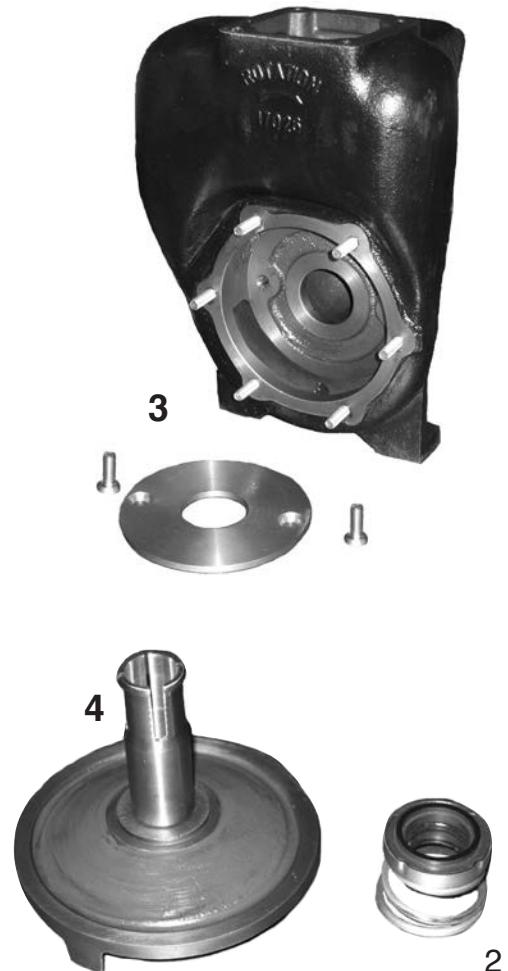

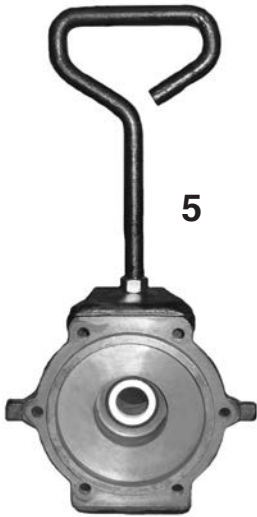

5. Remove the white ceramic seal and rubber cup from the rear adapter. Clean the recess opening with sandpaper or wire brush.

Install the new seal half.

Very important to not scratch or mark the white ceramic seal surface. It is usually helpful to apply a small amount of lubrication to the rubber cap and then press the seal into position, using your two thumbs or arbor press to press in evenly. Make sure the seal is in position straight and true to prevent seal wobble.



6. A shim is used to set the clearance between the impeller and wear plate. Any shim with a thickness of .030/.040 can be used. An ideal shim is a 1/2" wide piece of No. 21 gauge sheet metal.

Place the impeller and seal half assembly in position with impeller face against the banding material.



7. Install rear adapter using a new adapter gasket. Tighten (6) nuts.

8. Install pump to gas engine or bearing pedestal and tighten bolts.

Install bolted clamp and tighten bolts. The clamp bolts should be very tight. They should also be tightened equally so the space from side to side between clamps is equal for balance and to prevent vibration.

After all bolts are tight, grip the banding material and pull out.

After shim is removed the pump should turn freely.

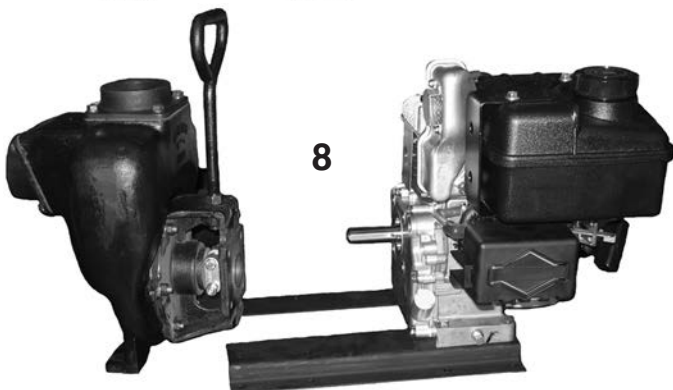

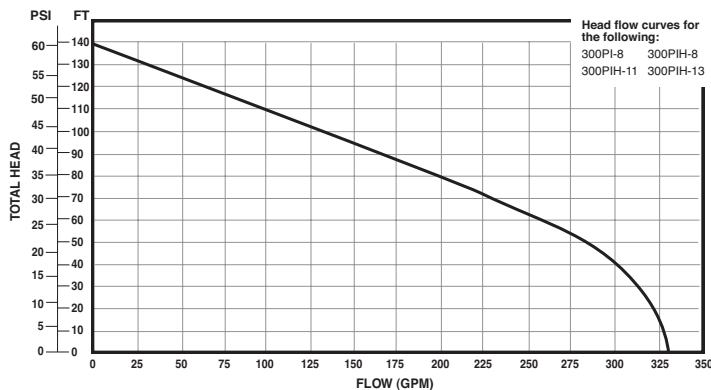
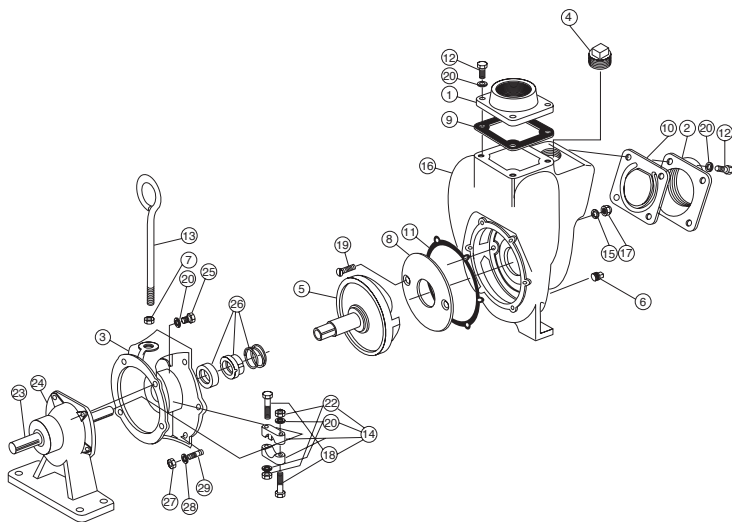

PERFORMANCE CHART @ 3450 RPM													
Head (FT)	0	11	23	34	46	57	69	80	92	103	115	126	138
Pressure (PSI)	0	5	10	15	20	25	30	35	40	45	50	55	60
Flow (GPM)	330	325	320	310	290	265	230	200	160	130	90	45	0

Note: Curve based on water and pump spinning at 3450 RPM

ITEM	PART NO.	DESCRIPTION
1	18008SS	Flange-Outlet 3"
2	18012SS	Flange-Inlet 3"
3	18026SS	Adapter-Gas Engine
3	18048SS	3" C-Flange Adapter
3	18049SS	3" C-Flange Hydraulic Motor Adapter
N/S	18055	Hydraulic Shaft Sleeve Adapter
N/S	18600SS	Hydraulic Motor Assembly
N/S	HY10121	Tyrone UM16 Hydraulic Motor
4	18002SS	Plug 1" NPT Flush
5	18023SS*	Impeller Drive Sleeve Assy.-1" Shaft Sleeve
5	18023-1.125SS	Impeller Drive Sleeve-1 1/8" Shaft Sleeve
6	18003SS	Drain Plug 1/4" NPT
7	18034	Nut, Jam 5/8" - 11 THD. S. S.
8	18004SS*	Plate-Wear
9	18044	Gasket-Outlet viton
10	18042	Gasket-Check Valve Assembly viton
11	18021*	Gasket-Adapter
12	18010SS	Capscrew Hex Hd. 3/8" - 16 x 1 1/8" Lg. S.S.
13	18033	Handle
14	18029	Clamp Assembly
15	18005*	Gasket-Wear Plate
16	18001SS	Pump Housing Stainless Steel
17	18007	Nut, Acorn
18	18030	Bolt, 3/8" - 24 x 2 1/4" Lg. S. S.
19	18006SS*	Bolt, 3/8" - 16 x 1 1/4" Lg. x 82° C'Sink S.S.
20	V20018	Lock Washer 3/8"
22	18032	Nut, 3/8" - 24 Hex. S.S.
23	18504	1" Shaft for 3" Pedestal
N/S	18502	Bearing (2 per Pedestal) (1 per Hydr. Adapt.)
N/S	18505	Shaft Key
24	18500	Bearing Pedestal Assembly
24	18501	Pedestal Housing Only
25	18027	Capscrew 3/8" - 16 x 1 1/2"
26	18025SS*	Viton Seal Assembly
27	18032	Nut, 3/8" - 24, Hex S.S.
28	V20018	Washer, 3/8" Lock S.S.
29	18018	Stud
N/S	18100SS	3" Pump Repair Kit (Items Marked*)
N/S	18035	Z-Rails (1 pair)

ITEM	PART NO.	DESCRIPTION
1	18008	Flange-Outlet 3"
2	18012	Flange-Inlet 3"
3	18026	Adapter-Gas Engine
3	18048	3" C-Flange Adapter
3	18049	3" C-Flange Hydraulic Motor Adapter
N/S	18055	Hydraulic Shaft Sleeve Adapter
N/S	18600	Hydraulic Motor Assembly
N/S	HY10121	Tyrone UM16 Hydraulic Motor
4	18002	Plug 1" NPT Flush
5	18023	Impeller Drive Sleeve Assy.-1" Shaft Sleeve
5	18023-1.125	Impeller Drive Sleeve-1 1/8" Shaft Sleeve
6	18003	Drain Plug 1/4" NPT
7	18034	Nut, Jam 5/8" - 11 THD. S. S.
8	18004*	Plate-Wear
9	18009	Gasket-Outlet EPDM
10	18013	Gasket-Check Valve Assembly EPDM
11	18021*	Gasket-Adapter
12	18010	Capscrew Hex Hd. 3/8" - 16 x 1 1/8" Lg. S.S.
13	18033	Handle
14	18029	Clamp Assembly
15	18005*	Gasket-Wear Plate
16	18001	Pump Housing
17	18007	Nut, Acorn
18	18030	Bolt, 3/8" - 24 x 2 1/4" Lg. S. S.
19	18006*	Bolt, 3/8" - 16 x 1 1/4" Lg. x 82° C'Sink S.S.
20	V20018	Lock Washer 3/8"
22	18032	Nut, 3/8" - 24 Hex. S.S.
23	18504	1" Shaft for 3" Pedestal
N/S	18502	Bearing (2 per Pedestal) (1 per Hydr. Adapt.)
N/S	18505	Shaft Key
24	18500	Bearing Pedestal Assembly
24	18501	Pedestal Housing Only
25	18027	Capscrew 3/8" - 16 x 1 1/2"
26	18025*	Viton Seal Assembly
27	18032	Nut, 3/8" - 24, Hex S.S.
28	V20018	Washer, 3/8" Lock S.S.
29	18018	Stud
N/S	18100	3" Pump Repair Kit (Items Marked*)
N/S	18035	Z-Rails (1 pair)

150 Banjo Drive  
Crawfordsville, IN 47933

TEL 765-362-7367  
FAX 800-458-0232

INT'L FAX 765-362-0744  
sales1@banjocorp.com

www.banjocorp.com